

LOC		DIST		REVISIONS			
CM	00	P	LTN	DESCRIPTION	DATE	DMN	APVD
		C		REVISED PER ECR-10-022954	03MAR2011	HMR	TM
		C1		REVISED PER ECR-14-001377	20APR2015	AV	DZ

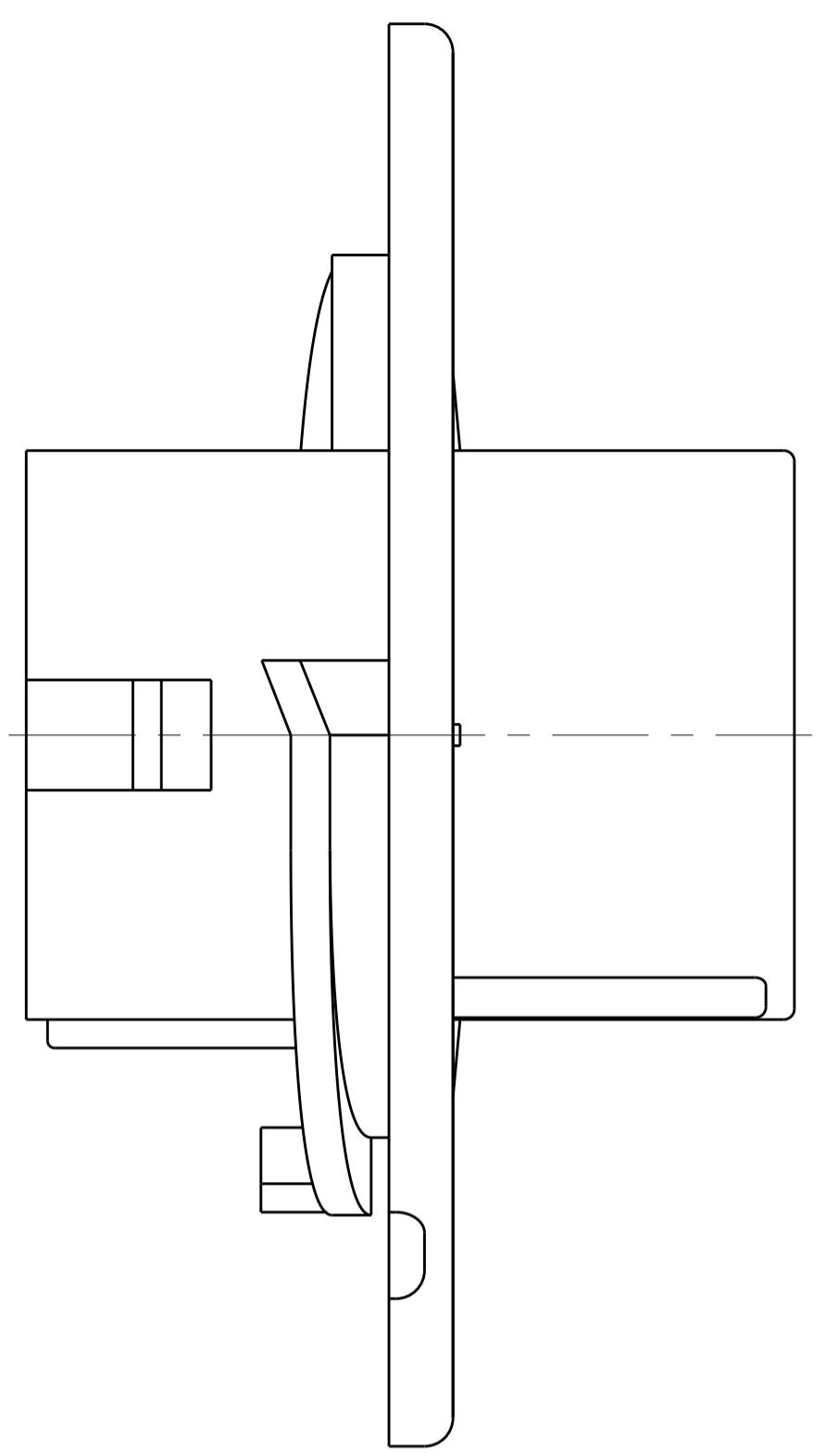

- MATES WITH APPROPRIATE UNIVERSAL MATE-N-LOK™ PLUG.
- RECOMMENDED PANEL THICKNESS 0.76 - 2.29 [0.030 - .090].
- PANEL MUST BE PUNCHED SO THAT THE HOUSING ENTERS THE PANEL IN THE SAME DIRECTION AS THE PUNCH.
- △ DIMENSIONS INDICATED ARE REFERENCE. ADDITIONAL GROWTH DUE TO SUBSEQUENT MOISTURE ABSORPTION MAY OCCUR.
- FLAMMABILITY V-2 FOR THICKNESS 0.38mm, 0.75mm, 1.5mm AND 3.0mm PER IEC 60695-11-10.
- GLOW-WIRE FLAMMABILITY (GWFI) 800°C FOR THICKNESS 0.38mm AND 0.75mm PER IEC 60695-2-12.
- GLOW-WIRE FLAMMABILITY (GWFI) 960°C FOR THICKNESS 1.5mm AND 3.0mm PER IEC 60695-2-12.
- GLOW-WIRE IGNITION (GWIT) 825°C FOR THICKNESS 0.38mm, 0.75mm, 1.5mm, AND 3.0mm PER IEC 60695-2-13.

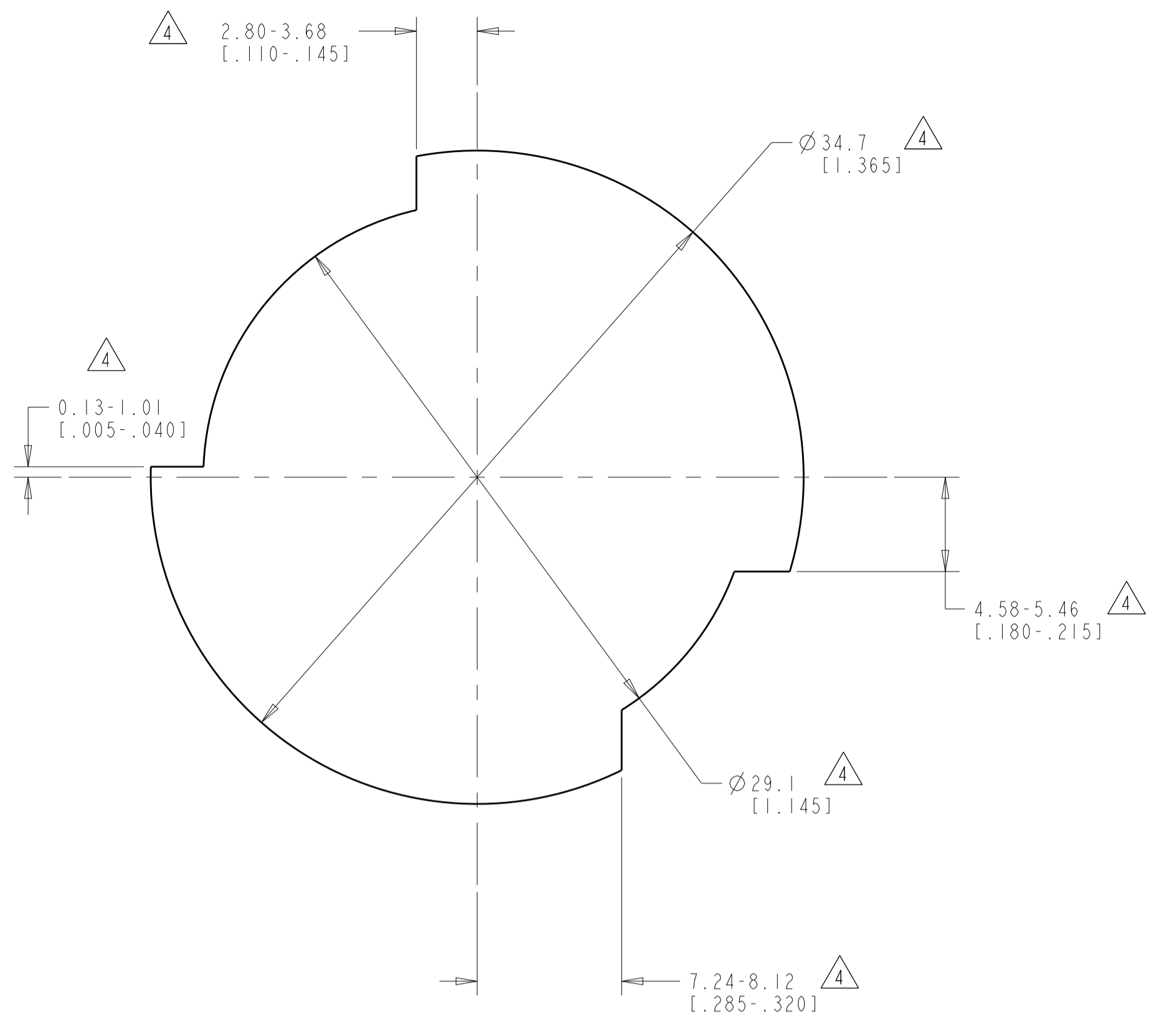
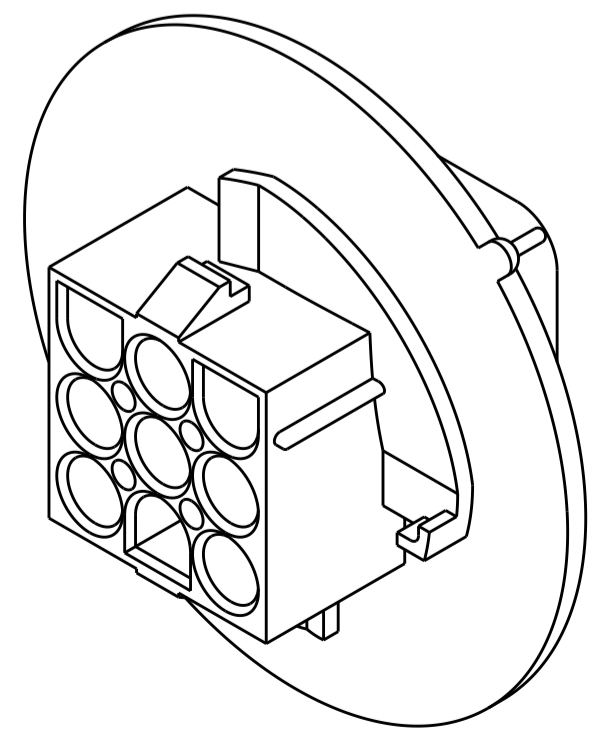
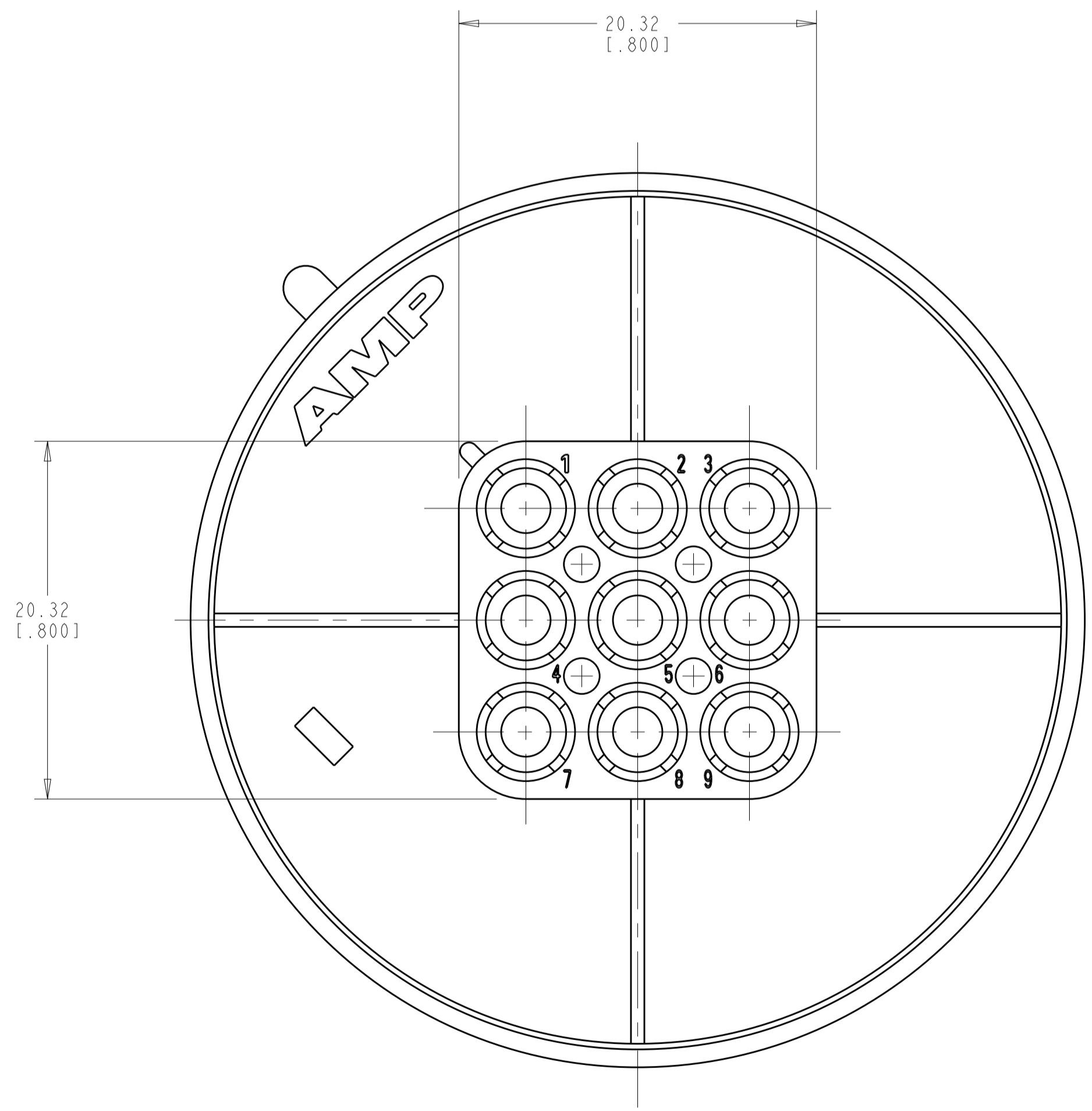
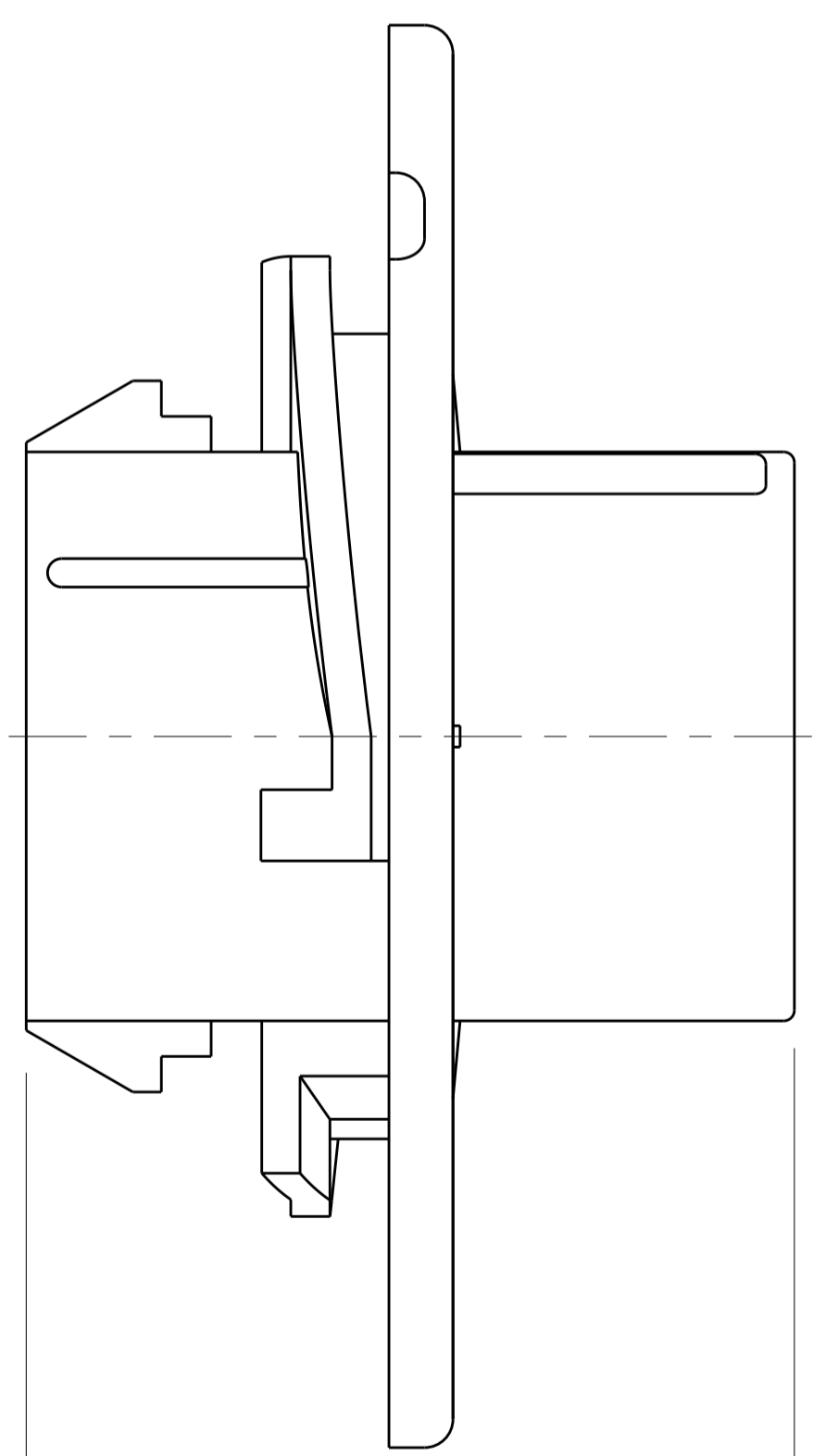
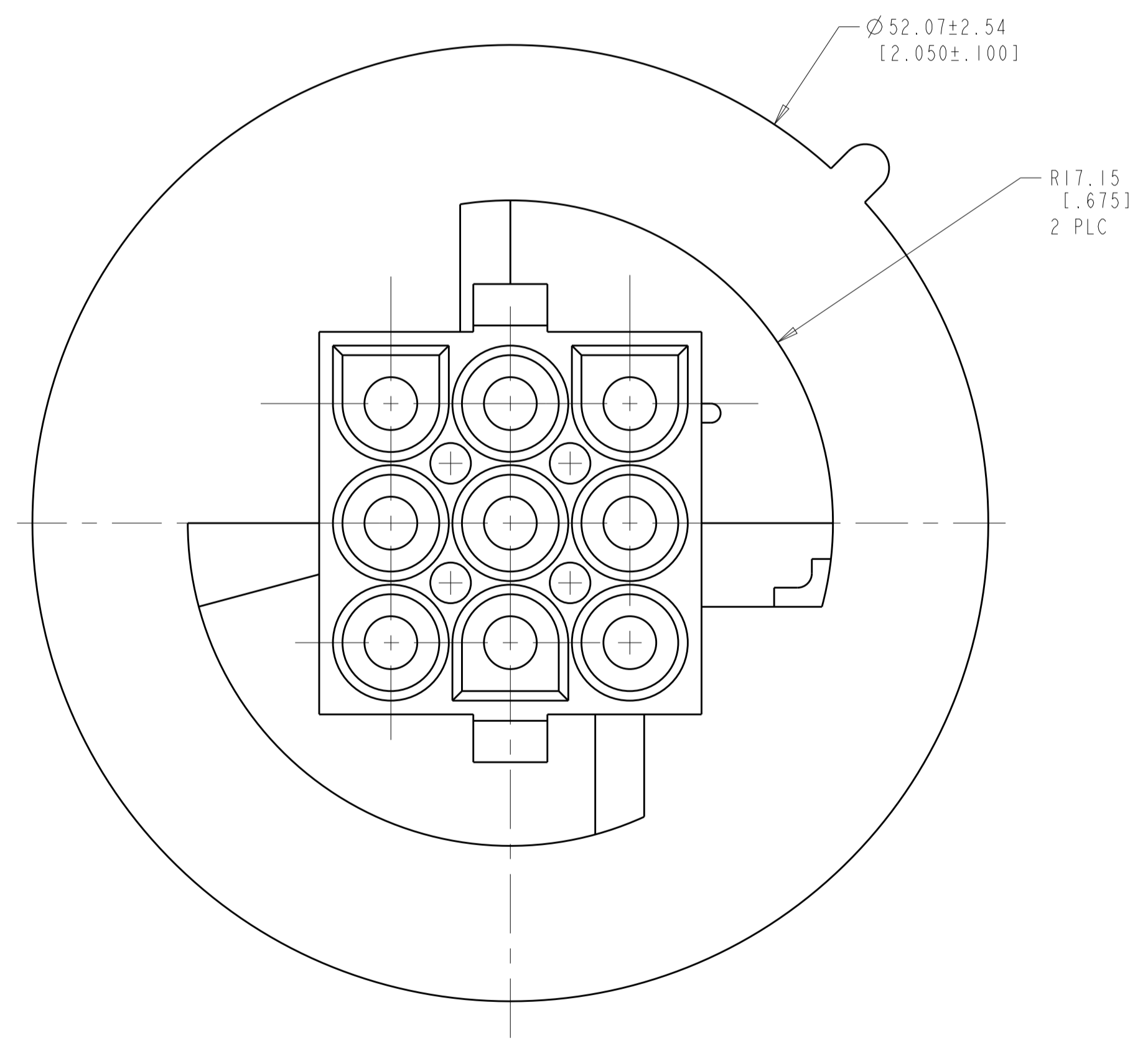

3-DIMENSIONAL MODEL SCALE 2:1

NATURAL	1586853-1
COLOR	PART NUMBER

THIS DRAWING IS A CONTROLLED DOCUMENT.		DMN	R. WHITAKER	18JUL2007
DIMENSIONS: mm [INCHES]		CHK	D. COLEY	18JUL2007
TOLERANCES UNLESS OTHERWISE SPECIFIED:		APVD	D. COLEY	18JUL2007
0 PLC	±	NAME		
1 PLC	±	CAP.		
2 PLC	±0.511(.020)	UNIVERSAL MATE-N-LOK(TM), SPECIAL		
3 PLC	±	PRODUCT SPEC		
4 PLC	±	APPLICATION SPEC		
ANGLES	±	SIZE CAGE CODE DRAWING NO		
FINISH	± 40° 30'	A1 00779 C=1586853		
MATERIAL	NYLON UL 94V-2, NATURAL	WEIGHT		
CUSTOMER DRAWING		SCALE 4:1 SHEET 1 OF 1 REV C1		

